



TO-92L Plastic-Encapsulate Transistors

2SA1013 TRANSISTOR (PNP)

FEATURE

- High Voltage: $V_{CEO} = -160V$
- Large Continuous Collector Current Capability
- Complementary to 2SC2383

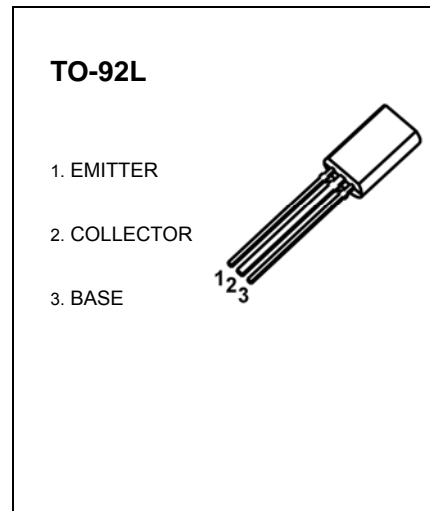

MAXIMUM RATINGS ($T_a = 25\text{ }^\circ\text{C}$ unless otherwise noted)

Symbol	Parameter	Value	Unit
V_{CBO}	Collector-Base Voltage	-160	V
V_{CEO}	Collector-Emitter Voltage	-160	V
V_{EBO}	Emitter-Base Voltage	-6	V
I_C	Collector Current -Continuous	-1	A
P_C	Collector Power Dissipation	0.9	W
T_j	Junction Temperature	150	$^\circ\text{C}$
T_{stg}	Storage Temperature	-55 to +150	$^\circ\text{C}$

ELECTRICAL CHARACTERISTICS ($T_a = 25^\circ\text{C}$ unless otherwise specified)

Parameter	Symbol	Test conditions	Min	Max	Unit
Collector-base breakdown voltage	$V_{(BR)CBO}$	$I_C = -100\mu\text{A}$, $I_E = 0$	-160		V
Collector-emitter breakdown voltage	$V_{(BR)CEO}$	$I_C = -1\text{mA}$, $I_B = 0$	-160		V
Emitter-base breakdown voltage	$V_{(BR)EBO}$	$I_E = -10\mu\text{A}$, $I_C = 0$	-6		V
Collector cut-off current	I_{CBO}	$V_{CB} = -150\text{V}$, $I_E = 0$		-1	μA
Emitter cut-off current	I_{EBO}	$V_{EB} = -6\text{V}$, $I_C = 0$		-1	μA
DC current gain	h_{FE}	$V_{CE} = -5\text{V}$, $I_C = -200\text{mA}$	60	320	
Collector-emitter saturation voltage	$V_{CE(sat)}$	$I_C = -500\text{mA}$, $I_B = -50\text{mA}$		-1.5	V
Base-emitter voltage	V_{BE}	$I_C = -5\text{mA}$, $V_{CE} = -5\text{V}$		-0.75	V
Transition frequency	f_T	$V_{CE} = -5\text{V}$, $I_C = -200\text{mA}$	15		MHz
Collector Output capacitance	C_{ob}	$V_{CB} = -10\text{V}$, $I_E = 0$, $f = 1\text{MHz}$		35	pF

CLASSIFICATION OF h_{FE}

Rank	R	O	Y
Range	60-120	100-200	160-320

Typical Characteristics

2SA1013

