



**TO-92 Plastic-Encapsulate Transistors**

**C1815** TRANSISTOR (NPN)

**FEATURES**

- Power dissipation

**MAXIMUM RATINGS (T<sub>a</sub>=25°C unless otherwise noted)**

Symbol	Parameter	Value	Unit
V <sub>CB0</sub>	Collector-Base Voltage	60	V
V <sub>CEO</sub>	Collector-Emitter Voltage	50	V
V <sub>EBO</sub>	Emitter-Base Voltage	5	V
I <sub>C</sub>	Collector Current -Continuous	150	mA
P <sub>C</sub>	Collector Power Dissipation	400	mW
R <sub>θJA</sub>	Thermal Resistance from Junction to Ambient	312	°C/W
T <sub>J</sub>	Junction Temperature	150	°C
T <sub>stg</sub>	Storage Temperature	-55~+150	°C

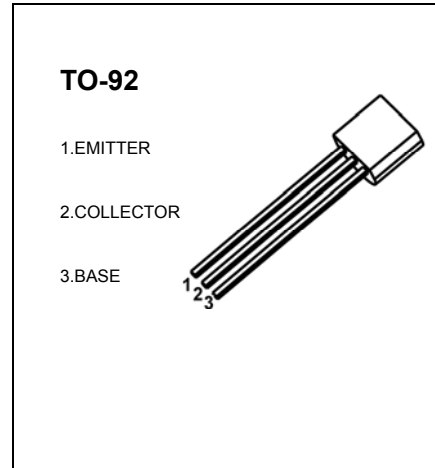

**ELECTRICAL CHARACTERISTICS (T<sub>a</sub>=25°C unless otherwise specified)**

Parameter	Symbol	Test conditions	Min	Typ	Max	Unit
Collector-base breakdown voltage	V <sub>(BR)CBO</sub>	I <sub>C</sub> = 100uA, I <sub>E</sub> =0	60			V
Collector-emitter breakdown voltage	V <sub>(BR)CEO</sub>	I <sub>C</sub> = 0.1mA, I <sub>B</sub> =0	50			V
Emitter-base breakdown voltage	V <sub>(BR)EBO</sub>	I <sub>E</sub> = 100uA, I <sub>C</sub> =0	5			V
Collector cut-off current	I <sub>CBO</sub>	V <sub>CB</sub> = 60V, I <sub>E</sub> =0			0.1	uA
Collector cut-off current	I <sub>CEO</sub>	V <sub>CE</sub> = 50V, I <sub>B</sub> =0			0.1	uA
Emitter cut-off current	I <sub>EBO</sub>	V <sub>EB</sub> =5V, I <sub>C</sub> =0			0.1	uA
DC current gain	h <sub>FE</sub>	V <sub>CE</sub> = 6 V, I <sub>C</sub> = 2mA	70		700	
Collector-emitter saturation voltage	V <sub>CE(sat)</sub>	I <sub>C</sub> =100mA, I <sub>B</sub> =10mA			0.25	V
Base-emitter saturation voltage	V <sub>BE(sat)</sub>	I <sub>C</sub> =100mA, I <sub>B</sub> =10mA			1	V
Transition frequency	f <sub>T</sub>	V <sub>CE</sub> =10 V, I <sub>C</sub> = 1mA f=30MHz	80			MHz
Collector Output Capacitance	C <sub>ob</sub>	V <sub>CB</sub> =10V, I <sub>E</sub> =0 f=1MHz			3.5	pF
Noise Figure	NF	V <sub>CE</sub> =6V, I <sub>C</sub> =0.1mA f =1KHz, R <sub>G</sub> =10K			10	dB

**CLASSIFICATION OF h<sub>FE</sub>**

Rank	O	Y	GR	BL
Range	70-140	120-240	200-400	350-700

# Typical Characteristics

# C1815

