



**TO-92 Plastic-Encapsulate Transistors**

**SS8050** TRANSISTOR (NPN)

**FEATURES**

- Power Dissipation  
 $P_{CM} : 1\text{ W (}T_A=25.\text{)}$   
 $: 2\text{ W (}T_C=25.\text{)}$

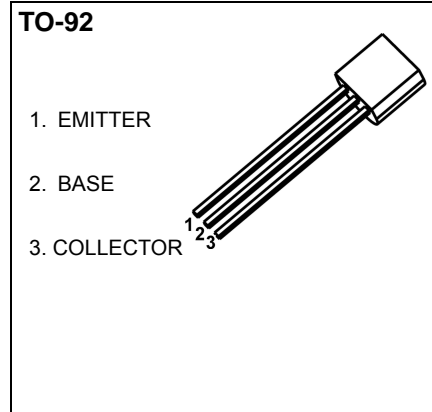

**MAXIMUM RATINGS ( $T_a=25^\circ\text{C}$  unless otherwise noted)**

| Symbol    | Parameter                     | Value   | Unit             |
|-----------|-------------------------------|---------|------------------|
| $V_{CBO}$ | Collector-Base Voltage        | 40      | V                |
| $V_{CEO}$ | Collector-Emitter Voltage     | 25      | V                |
| $V_{EBO}$ | Emitter-Base Voltage          | 5       | V                |
| $I_C$     | Collector Current -Continuous | 1.5     | A                |
| $T_j$     | Junction Temperature          | 150     | $^\circ\text{C}$ |
| $T_{stg}$ | Storage Temperature           | -55-150 | $^\circ\text{C}$ |

**ELECTRICAL CHARACTERISTICS ( $T_a=25^\circ\text{C}$  unless otherwise specified)**

| Parameter                            | Symbol        | Test conditions                                      | Min | Typ | Max | Unit          |
|--------------------------------------|---------------|--|-----|-----|-----|---------------|
| Collector-base breakdown voltage     | $V_{(BR)CBO}$ | $I_C=100\mu\text{A}, I_E=0$                          | 40  |     |     | V             |
| Collector-emitter breakdown voltage  | $V_{(BR)CEO}$ | $I_C=0.1\text{mA}, I_B=0$                            | 25  |     |     | V             |
| Emitter-base breakdown voltage       | $V_{(BR)EBO}$ | $I_E=100\mu\text{A}, I_C=0$                          | 5   |     |     | V             |
| Collector cut-off current            | $I_{CBO}$     | $V_{CB}=40\text{V}, I_E=0$                           |     |     | 0.1 | $\mu\text{A}$ |
| Emitter cut-off current              | $I_{CEO}$     | $V_{CE}=20\text{V}, I_E=0$                           |     |     | 0.1 | $\mu\text{A}$ |
| Emitter cut-off current              | $I_{EBO}$     | $V_{EB}=5\text{V}, I_C=0$                            |     |     | 0.1 | $\mu\text{A}$ |
| DC current gain                      | $h_{FE(1)}$   | $V_{CE}=1\text{V}, I_C=100\text{mA}$                 | 85  |     | 400 |               |
|                                      | $h_{FE(2)}$   | $V_{CE}=1\text{V}, I_C=800\text{mA}$                 | 40  |     |     |               |
| Collector-emitter saturation voltage | $V_{CE(sat)}$ | $I_C=800\text{mA}, I_B=80\text{mA}$                  |     |     | 0.5 | V             |
| Base-emitter saturation voltage      | $V_{BE(sat)}$ | $I_C=800\text{mA}, I_B=80\text{mA}$                  |     |     | 1.2 | V             |
| Base-emitter voltage                 | $V_{BE}$      | $V_{CE}=1\text{V}, I_C=10\text{mA}$                  |     |     | 1   | V             |
| Transition frequency                 | $f_T$         | $V_{CE}=10\text{V}, I_C=50\text{mA}, f=30\text{MHz}$ | 100 |     |     | MHz           |

**CLASSIFICATION OF  $h_{FE(1)}$**

| Rank  | B      | C       | D       | D3      |
|-------|--------|---------|---------|---------|
| Range | 85-160 | 120-200 | 160-300 | 300-400 |

# Typical Characteristics

# SS8050

