



TO-220-3L Plastic-Encapsulate Transistors

TIP120,121,122 Darlington TRANSISTOR (NPN)

TIP125,126,127 Darlington TRANSISTOR (PNP)

FEATURES

- Medium Power Complementary Silicon Transistors

MAXIMUM RATINGS (T_a=25°C unless otherwise noted)

Symbol	Parameter	TIP120	TIP121	TIP122	Unit
		TIP125	TIP126	TIP127	
V _{CBO}	Collector-Base Voltage	60	80	100	V
V _{CEO}	Collector-Emitter Voltage	60	80	100	V
V _{EBO}	Emitter-Base Voltage	5			V
I _C	Collector Current -Continuous	5			A
P _C	Collector Power Dissipation	2			W
R _{θJA}	Thermal Resistance Junction to Ambient	62.5			°C/W
R _{θJc}	Thermal Resistance Junction to Case	1.92			°C/W
T _J	Junction Temperature	150			°C
T _{stg}	Storage Temperature	-55to+150			°C

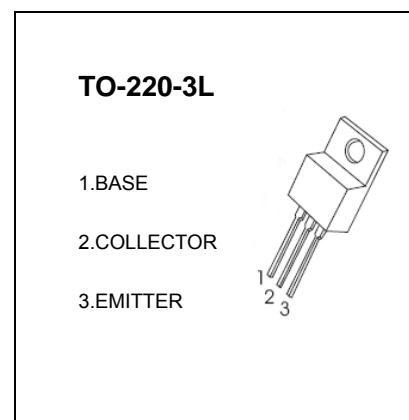

ELECTRICAL CHARACTERISTICS (T_a=25°C unless otherwise specified)

Parameter	Symbol	Test conditions	Min	Max	Unit
Collector-base breakdown voltage	TIP120,TIP125 TIP121,TIP126 TIP122,TIP127	V _{(BR)CBO}	I _C = 1mA, I _E =0	60 80 100	V
Collector-emitter breakdown voltage	TIP120,TIP125 TIP121,TIP126 TIP122,TIP127	V _{CEO(SUS)}	I _C = 30mA, I _B =0	60 80 100	V
Collector cut-off current	TIP120,TIP125 TIP121,TIP126 TIP122,TIP127	I _{CBO}	V _{CB} = 60 V, I _E =0 V _{CB} = 80 V, I _E =0 V _{CB} = 100V, I _E =0	0.2	mA
Collector cut-off current	TIP120,TIP125 TIP121,TIP126 TIP122,TIP127	I _{CEO}	V _{CE} =30 V, I _B =0 V _{CE} =40 V, I _B =0 V _{CE} =50 V, I _B =0	0.5	mA
Emitter cut-off current		I _{EBO}	V _{EB} =5 V, I _C =0	2	mA
DC current gain		h _{FE(1)}	V _{CE} = 3V, I _C =0.5A	1000	
		h _{FE(2)}	V _{CE} = 3V, I _C =3 A	1000	
Collector-emitter saturation voltage		V _{CE(sat)}	I _C =3A, I _B =12mA I _C =5 A, I _B =20mA	2 4	V
Base-emitter voltage		V _{BE}	V _{CE} =3V, I _C =3 A	2.5	V
Output Capacitance	TIP125,TIP126,TIP127 TIP120,TIP121,TIP122	C _{ob}	V _{CB} =10V, I _E =0, f=0.1MHz	300 200	pF