



4GBJ4005 thru 4GBJ410

GLASS PASSIVATED BRIDGE RECTIFIERS

REVERSE VOLTAGE - 50 to 1000Volts
 FORWARD CURRENT - 4.0 Amperes

FEATURES

- Surge overload rating -150 amperes peak
- Ideal for printed circuit board
- Reliable low cost construction utilizing molded plastic technique
- The plastic material has UL flammability classification 94V-0
- Mounting position:Any

4GBJ

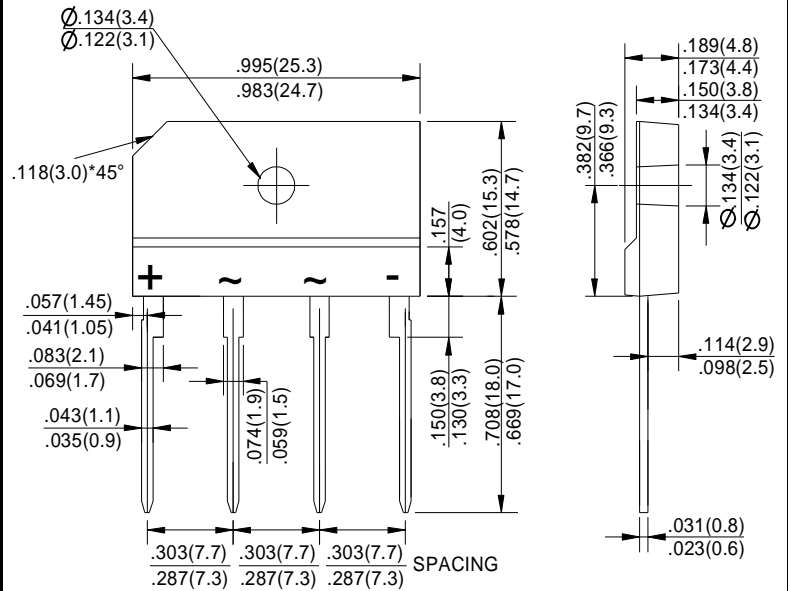

Dimensions in inches and (millimeters)

MAXIMUM RATINGS AND ELECTRICAL CHARACTERISTICS

Rating at 25°C ambient temperature unless otherwise specified.

Single phase, half wave, 60Hz, resistive or inductive load.

For capacitive load, derate current by 20%

CHARACTERISTICS	SYMBOL	4GBJ 4005	4GBJ 401	4GBJ 402	4GBJ 404	4GBJ 406	4GBJ 408	4GBJ 410	UNIT
Maximum Recurrent Peak Reverse Voltage	V _{RRM}	50	100	200	400	600	800	1000	V
Maximum RMS Voltage	V _{RMS}	35	70	140	280	420	560	700	V
Maximum DC Blocking Voltage	V _{DC}	50	100	200	400	600	800	1000	V
Maximum Average Forward Rectified Current @ T _C =100°C (with heatsink Note 2) @ T _C =100°C (without heatsink)	I _(AV)	4.0 2.4							A
Peak Forward Surge Current 8.3ms Single Half Sine-Wave Super Imposed on Rated Load (JEDEC Method)	I _{FSM}	120							A
Maximum Forward Voltage at 4.0A DC	V _F	1.1							V
Maximum DC Reverse Current at Rated DC Blocking Voltage @ T _J =25°C @ T _J =125°C	I _R	10.0 500							µA
I ² t Rating for Fusing (t<8.3ms)	I ² t	93							A ² s
Typical Junction Capacitance Per Element (Note1)	C _J	45							pF
Typical Thermal Resistance	R _{θJC}	2.2							°C/W
Operating Temperature Range	T _J	-55 to +150							°C
Storage Temperature Range	T _{STG}	-55 to +150							°C

NOTES: 1.Measured at 1.0MHz and applied reverse voltage of 4.0V DC.

2.Device mounted on 50mm*50mm*1.6mm Cu plate heatsink.

RATING AND CHARACTERISTIC CURVES
4GBJ4005 thru 4GBJ410



FIG.1-FORWARD CURRENT DERATING CURVE

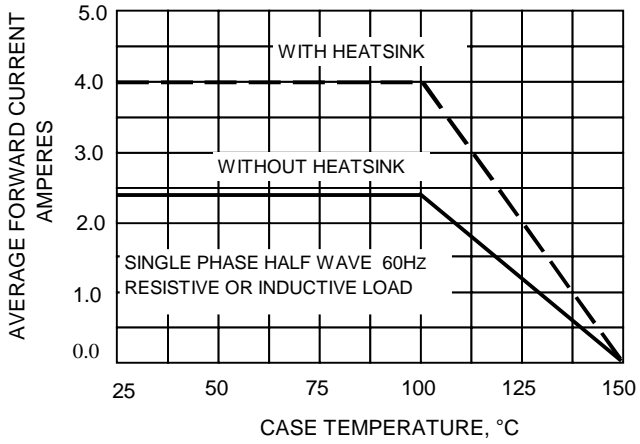

FIG.2-MAXIMUM NON-REPETITIVE SURGE CURRENT

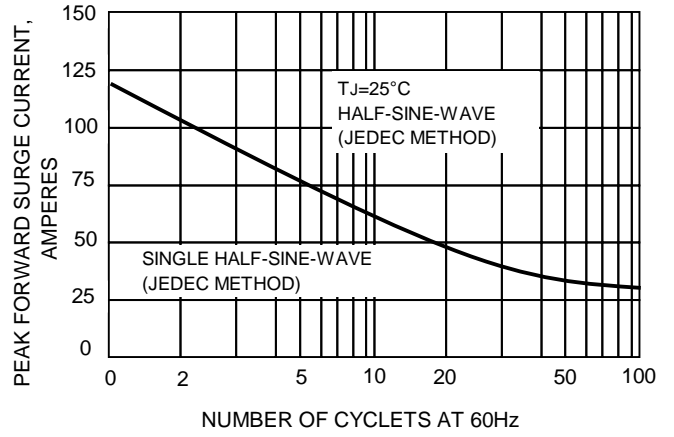

FIG.4-TYPICAL FORWARD CHARACTERISTICS

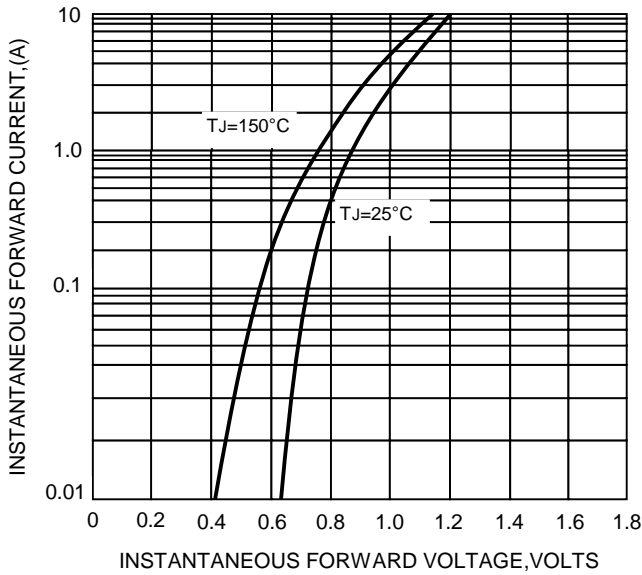

FIG.5-TYPICAL REVERSE CHARACTERISTICS

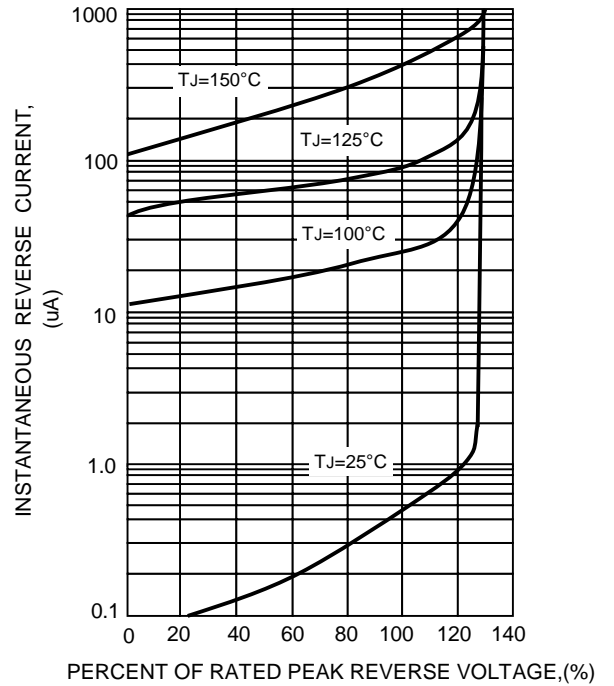

FIG.5-TYPICAL JUNCTION CAPACITANCE

